

Production Discharge Systems Specifications and Dimensions

STANDARD FEATURES

- Rugged steel support frame
- Hydraulically operated platen for accurate discharge control
- Hydraulic power-pak which can be mounted and plumbed, or supplied for remote installation
- Stainless steel type 304 platen
- Mix can positioning devices

OPTIONAL FEATURES

- Platen of type 316 stainless steel, alternate materials and coatings available
- Jacketed platen
- Sanitary construction
- Metering systems for accurate filling of packaging containers
- A variety of elastomers to wipe mix can walls
- High pressure designs for highly viscous/dense materials
- Pressure compensating power units for continuous or extended use

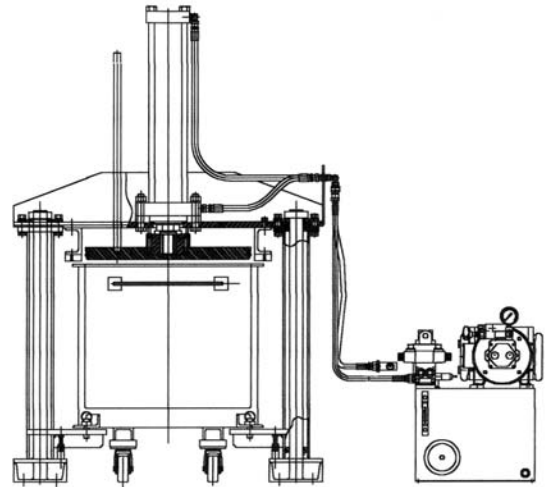

Floor Model

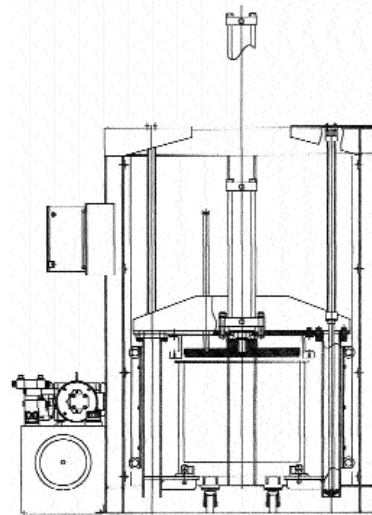

Elevated Model

| Model | Base Width | Base Depth | Overall Maximum Height |
|---------------------------------|------------|------------|------------------------|
| HED-10 - Elevated Design | 69 | 36 | 87 |
| HED-40 | 80 1/2 | 36 | 108 1/2 |
| HED-100 | 97 | 54 | 132 |
| HED-200 | 109 | 54 | 148 |
| DS-10 - Floor Design | 36 | 20 1/2 | 51 |
| DS-40 | 47 | 27 | 73 |
| DS-100 | 57 | 38 | 90 |
| DS-200 | 72 | 47 1/2 | 106 |
| All dimensions in inches | | | |

DIS 0102



Charles Ross & Son Company

P.O.Box 12308, 710 Old Willets Path, Hauppauge, NY 11788 - Tel: 1-631-234-0500 - Fax: 1-631-234-0691

Website: www.mixers.com - Email: sales@mixers.com